



MULTISPORT INSTALLATION AND MAINTENANCE MANUAL

Obsah

1.	Storage and Handling	5
1.1.	Type and Means of Handling	5
1.2.	Storage Guidelines	5
2.	Sub-base Construction	6
3.	Artificial Turf Installation	8
3.1.	Climatic Conditions	8
3.2.	Instructions for Artificial Turf Installation	8
3.3.	Laying of Artificial Turf	9
3.3.1.	Preparation	9
3.3.2.	Gluing	10
3.3.3.	Line Marking	12
3.3.4.	Infill (depending on the type of turf)	13
4.	Tools Required for Installation	14
5.	Maintenance of Artificial Turf	15
5.1.	Keeping a Maintenance Log	15
5.2.	Brushing the Surface	15
5.2.1.	Procedure for Brushing the Artificial Turf Surface	16
5.3.	Replenishing the Infill	16
5.4.	Cleaning and Inspecting the Joints	16
5.5.	Snow Removal	16
5.6.	Artificial Turf Inspection	17
6.	Conditions of Use	
	JUTAgass[®] Artificial Turf	18
7.	Appendix – Cross-Section Examples	19
7.1.	Structure with Asphalt Layer	19
7.2.	Structure with Poured Elastic Base Layer	20
8.	Instruction Sheet	21

www.jutagrass.cz

This document serves as a basic source of information for planners, contractors, and investors. It does not replace project documentation (or contractual documents) and is intended as a recommendation only. In light of the continuous improvement of products and technological processes, the information contained herein may be changed by JUTA a.s. without prior notice.

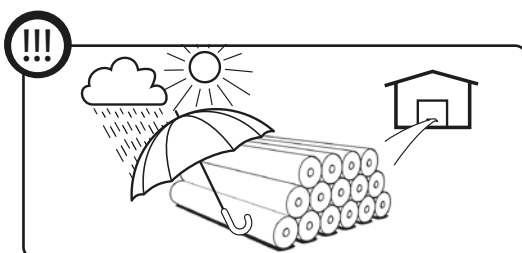
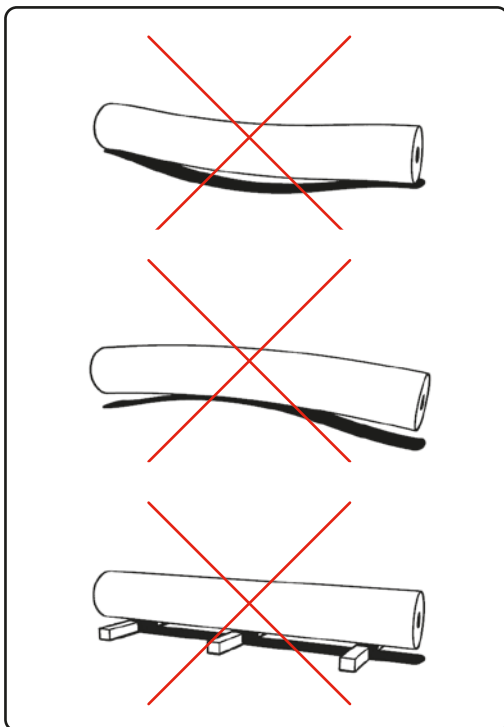
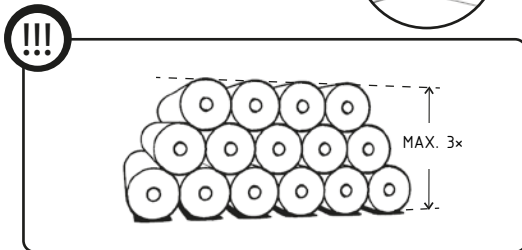
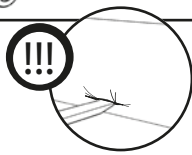
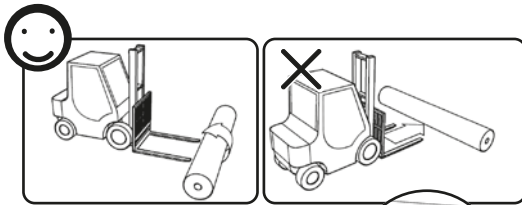
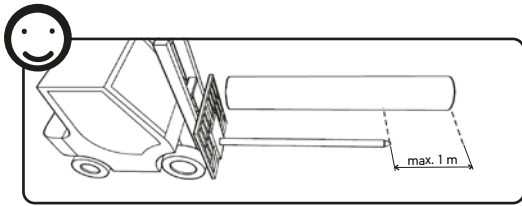

1. Storage and Handling

Compliance with the following guidelines prevents the possibility of damage and preserves the quality and properties of the product.

1.1. Type and Means of Handling

- For unloading and handling of the rolls, we recommend using lifting equipment with a steel spike of at least 3 m in length.
- If only lifting equipment with forks is available, we recommend rolling the turf rolls onto the forks to avoid puncturing.
- Special care must be taken during loading, unloading, and other handling of the material to prevent mechanical damage. We recommend performing loading and unloading using equipment with a steel spike and a ramp to minimize the risk of damage.
- During transport, it must be ensured that the tension straps are properly padded to avoid damaging the material.

Note: When following the above recommendations, generally applicable occupational safety regulations must also be observed.

1.2. Storage Guidelines

- Artificial turf should ideally be stored in covered, dry, dust-free, and well-ventilated rooms – for a maximum of 6 months.
- If the rolls are stored outdoors, they must be adequately protected from sunlight, wind, and rain.
- Rolls must be stored on a firm, stable, level, and well-drained surface (e.g., asphalt or concrete) – in a maximum of 3 layers stacked on top of each other.
- Each roll must be supported along its entire length. During storage, the rolls must not be subjected to any mechanical loads (especially bending), in order to avoid damage, deformation, or quality degradation.
- The recommended storage temperature is between 5 °C and 25 °C with relative humidity of up to 60%.
- The storage temperature of the material must not fall below -20 °C or exceed 40 °C. If lower or higher temperatures are expected, the material must be adequately protected (e.g., with covers).
- If rolls are stored outdoors but installed indoors, they must be brought into the installation area at least 24 hours before installation for acclimatization (this is especially important in cold weather; the relaxation time depends on climatic conditions).
- Stored rolls must not be exposed to thermal stress or direct sunlight.
- Artificial turf must not be stored together with chemicals or other substances whose chemical compatibility with the material is not guaranteed.
- The storage duration should be limited to the necessary minimum.

Failure to follow the above rules can lead to damage and devaluation of the artificial turf. Using appropriate handling and transport equipment and following proper procedures during transport, storage, and handling preserves the quality of JUTAgrass products. **Claims for damage due to improper handling or storage cannot be accepted.**

2. Subbase Construction

The requirements and composition of the subbase construction are determined by the planner or architect based on a geotechnical report and corresponding assessment. The following requirements are based on the standard DIN 18035-7.

Flatness Requirements for the individual subbase layers

(measured using a 4 m straightedge)

Existing soil	± 30 mm
Base layer	± 20 mm
Levelling layer	± 10 mm

Minimum Compaction Level for the individual subbase layers

	Deformation Modulus Static - E_{v2}
Subgrade	25 MPa
Structural layers	45 MPa
Verification of Layer Properties	Static Test

A prerequisite for executing construction works on paved areas is compliance with the minimum subgrade deformation modulus value of $E_{def,2} = 25$ MPa. Verification of the deformation modulus must be carried out by static plate load testing in accordance with applicable standards.

The formation level (subgrade) must be constructed to the specified transverse and longitudinal gradients and elevation tolerances, and in full accordance with the layout and alignment design. The subgrade must provide effective drainage (if required) and must exhibit a smooth, even, and homogeneous surface that satisfies surface regularity requirements. In the entire thickness of the active zone, the prescribed compaction degree of min. 95 % PS (Proctor Standard) must be maintained. On the subgrade, the minimum value of the deformation modulus from the second loading cycle must reach $E_{def,2} = 25$ MPa. Before carrying out the construction layers, the earth subgrade must be cleaned, and the work on laying the construction layers must not be started without the acceptance of the subgrade.

Technical data sheets, certificates, test reports, and declarations of conformity must be attached to all materials used. The bulk materials used for construction layers must comply with the standard requirements for the construction of sports fields.

The base under the artificial turf must be firm, continuous, bonded, without sharp edges and protrusions, local irregularities, and without any chemical or mechanical impurities. If the base does not meet these requirements, it must be adjusted.

At the end of this manual, possible structures of sports field constructions suitable for artificial turf installation are provided. If the artificial turf is installed on another type of sub-base construction, the JUTAgrass technical department must be contacted.

The contractor of the sub-base construction is responsible for its execution in accordance with the required technical standards and the project documentation.

The construction supervisor should continuously check and approve the following parameters of the sub-base construction:

- Inspection of correct execution and compliance with the project documentation.
- The individual layers of the sub-base construction are executed in the required thicknesses and fractions.
- The directions and slopes within the sub-base construction correspond to the project requirements.
- The layers of the sub-base construction meet the requirements for the degree of compaction, deformation modulus, flatness, etc.
- On the prepared sub-base, there are no sharp edges, puddles (poor drainage system), ruts from construction machinery, or traces of auxiliary leveling materials that need to be filled and compacted.
- In the case of installation on an asphalt slab, the surface must be properly ventilated. This process takes approximately 10–14 days from the installation of the last asphalt layer, depending on the climatic conditions.

Before starting the installation of the artificial turf, we recommend drawing up a protocol on the acceptance of the sub-base construction, stating the current condition of the sub-base construction. This document must be signed by all parties involved.

The manufacturer of the artificial turf recommends, upon acceptance of the sub-base construction, an inspection according to the following points:

- Inspection of subgrade permeability
- The layers of the sub-base construction meet the requirements for the degree of compaction, deformation modulus, and flatness.
- The directions and slopes within the sub-base construction correspond to the project requirements.

3. Artificial turf installation

3.1. Climatic conditions

The overall quality and compactness of the surface depend on installation under suitable climatic conditions. After unpacking and unrolling the artificial turf, it is essential to allow the rolls to rest (relax), so that they adapt to the ambient temperature and release any internal tension. Turf relaxation is particularly important when temperatures are very high or very low, or when there are large fluctuations between them (day/night). When the turf temperature is below 10 °C and there is a lack of sunlight, it is important to allow the turf to rest for a sufficiently long period.

We recommend carrying out turf installation (unrolling) at temperatures above 10 °C. At lower temperatures, the turf becomes stiffer, less flexible, and more difficult to handle during installation. The gluing of turf strips and line marking must be carried out under the conditions specified by the adhesive manufacturer. The application of sand infill must not take place during rain or snowfall.

3.2. Instructions for artificial turf installation

When installing artificial turf, hereinafter referred to as AT, the following instructions must be observed:

- During the installation of individual strips, only such construction machinery may be used that does not damage the sub-base construction and follows these rules:
 - The lifting capacity of the machine must be sufficient in relation to the weight of the rolls.
 - It must move slowly.
 - It must move in curves with sufficient radii.
 - It must not start or brake abruptly.
 - It must have low-pressure wide tires with a low profile.
 - The maximum permitted axle load of the machinery is 1,000 kg.
- If the rolls are stored outdoors and the installation itself takes place indoors, the rolls must be moved to the installation site well in advance for acclimatization (particularly important in cold weather).
- When handling a roll of artificial turf by rolling, it is necessary to pay attention to the winding direction; when rolled in the opposite direction, the roll loosens and creases and folds appear in the turf.
- AT rolls must be unrolled in a controlled and safe manner.
- All damages to the AT occurring during installation must be properly repaired.
- For a potential claim, it is necessary to provide photo documentation, the roll label, and also immediately inform the responsible person, who will contact the manufacturer. It is forbidden to further work with the material subject to the claim (cutting, gluing).

On the artificial turf and in its immediate vicinity, the following safety measures must be observed:

- No smoking
- No handling of hot objects
- No cutting or grinding of metals
- No welding of metals and handling of open flames

3.3. Laying of Artificial Turf

Before laying the artificial turf, it is necessary to inspect the sub-base construction and prepare a written record of this inspection.

3.3.1. Preparation

Placement and orientation of individual rolls on the surface according to the installation plan.

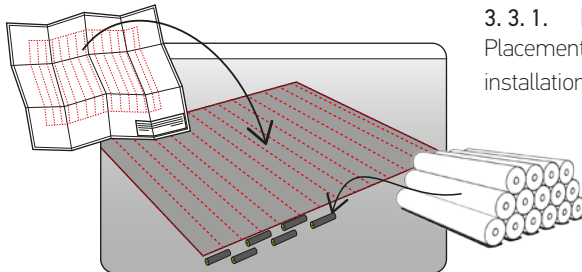

Unroll the artificial turf onto the surface either manually or using machinery.

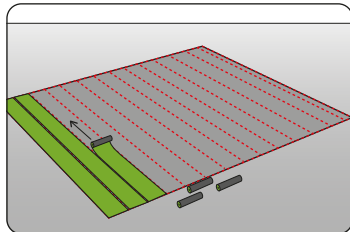

All turf strips must be oriented in the same direction.

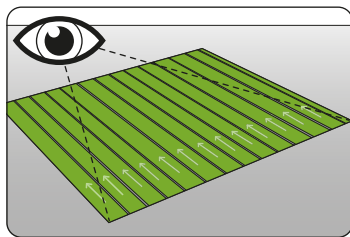

Depending on the chosen method for securing the turf edges (see below), leave an overlap of at least 10 cm.

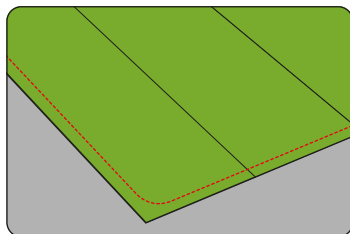

After unrolling the roll, the turf must be allowed to acclimatize; the relaxation time depends on climatic conditions, the method, and the length of storage. The recommended relaxation time is 24 hours. Make sure that no creases appear in the turf during installation.

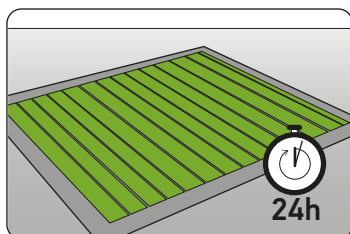

Before starting cutting, check the quality of the turf. If visible defects are found on the rolls, the installation must not continue until these defects are removed. Cut off the edges with fabric from each strip of turf, including the outer row of stitches. Make the cut at the inner side of the remaining stitch.

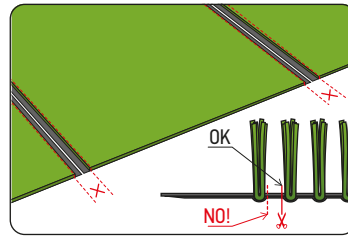

To cut off the edge, fold the turf back approximately 30 cm. Perform the cut on the backside using a special cutter or a sharp snap-off knife.

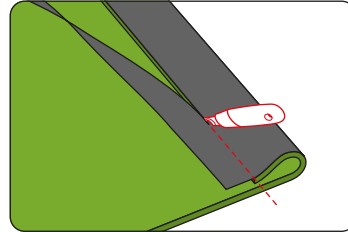

Place the cut strips of turf together. Leave a gap between the individual strips of turf not exceeding the width between the rows of fibers. The strips of turf must not overlap; they must be sufficiently stretched, without waves or irregularities.

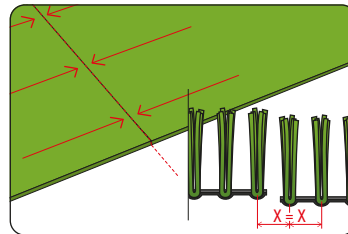

3.3.2. Gluing

Make the turf joints using an adhesive approved by the artificial turf manufacturer.



Before gluing, it is necessary to check again the tension of the turf and the width of the gap between the turf strips.

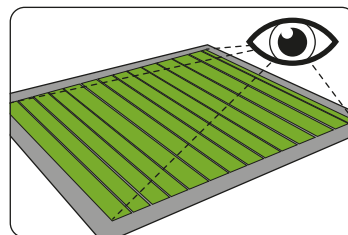

Fold back the edges of both turf strips to the backside. The size of the fold should approximately correspond to the width of the tape used.

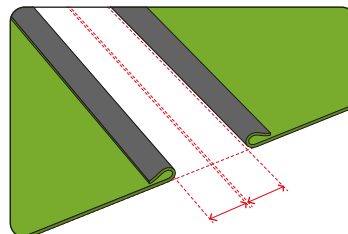

Insert the tape between the folded-back edges. The commonly used tape width is 30 cm.

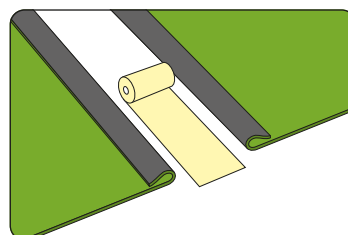

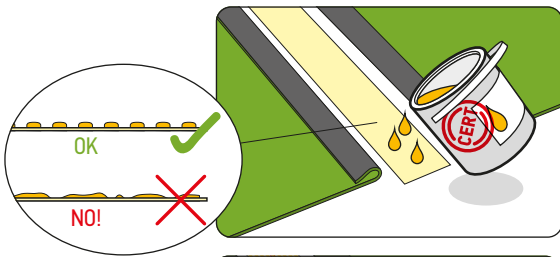

Apply an even layer of adhesive onto the tape. The adhesive can be applied using an applicator or a notched trowel with a minimum width of 20 cm. When applying the adhesive, it is necessary to prevent areas with excess or insufficient adhesive.

The notched trowels and blades used in the adhesive applicator must be checked to avoid changes in adhesive dosing. After approximately 700 m of joints, we recommend replacing the tools (blades).

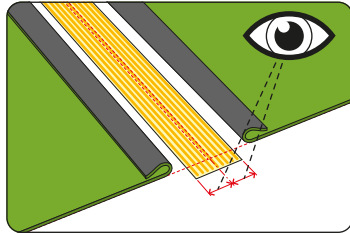

Before folding back the turf edges, it is necessary to center and stretch the tape with adhesive.

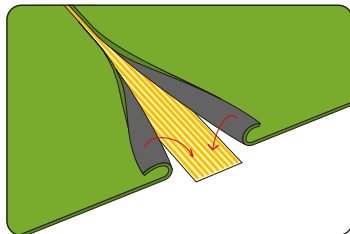

Before placing the turf onto the adhesive, check the correct amount of adhesive by imprinting (the adhesive must be imprinted over the entire backside). Then carefully press the turf edges into the adhesive. During gluing, it is important to prevent the turf from becoming contaminated with adhesive. If this occurs, the adhesive must be removed from the turf exclusively with products approved by the manufacturer to avoid damaging the AT.

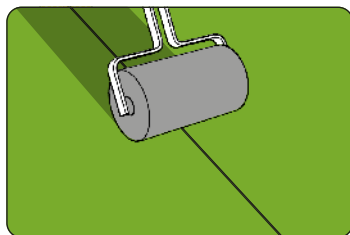

For a perfect bonding of the surfaces, the joint must be rolled or tamped at the time when the adhesive begins to react (this time depends on the climatic conditions).

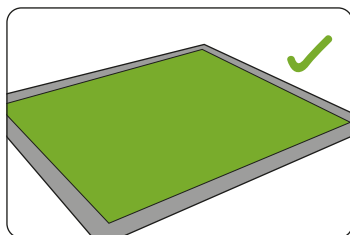

After the adhesive has completely dried and hardened, it is possible to start with securing the turf along the perimeter of the area and line marking the field. The curing time of the adhesive is specified on the adhesive label and depends on the climatic conditions.

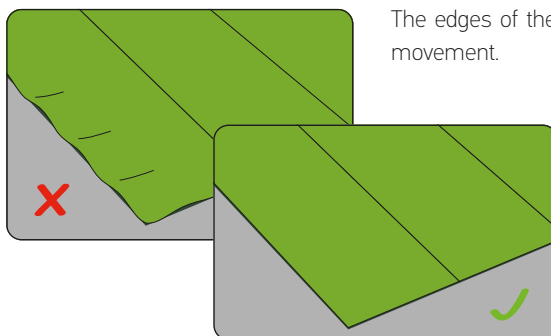

The edges of the turf area must be properly secured and fixed to prevent movement.

3.3.3. Line Marking

After the adhesive has hardened, begin measuring and cutting the lines.

The rolls with lines must be cut into individual lines of the required width. The cut is made along the stitch, and the sections between the rows of stitches must be removed.

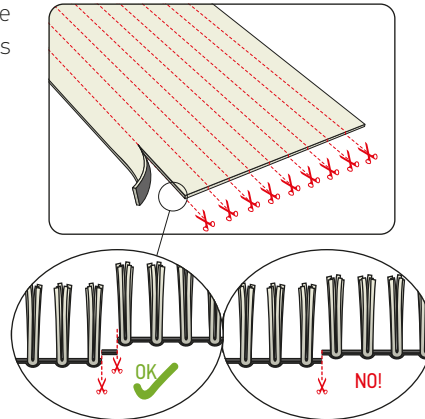

After cutting into individual lines, we recommend leveling/stretching the material and allowing it to relax.

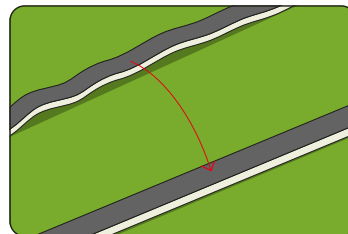

Measuring the field line marking is very important; therefore, devote sufficient time to this step.

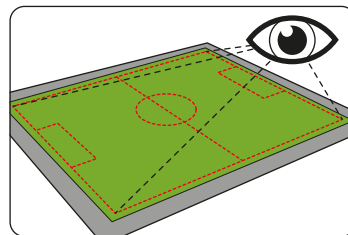

At the locations of the measured lines, carefully make the cut, which must always be slightly wider than the line width. The maximum permitted gap between the line and the turf equals the distance between the individual rows of turf stitches.

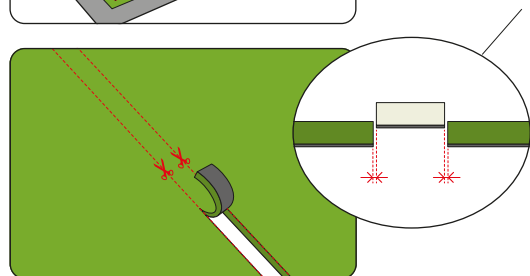

The procedure then follows the chapter Gluing.

Fold back the edges of both turf strips to the backside. The size of the fold should approximately correspond to the width of the tape used.

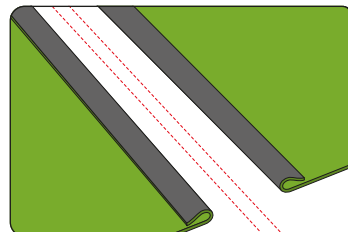

Apply an even layer of adhesive onto the tape. The adhesive can be applied using an applicator or a notched trowel with a width of 28 cm. When applying the adhesive, it is necessary to prevent areas with excess or insufficient adhesive. The notched trowels and blades used in the adhesive applicator must be checked to avoid changes in adhesive dosing. After approximately 700 m of joints, we recommend replacing the tools (blades).

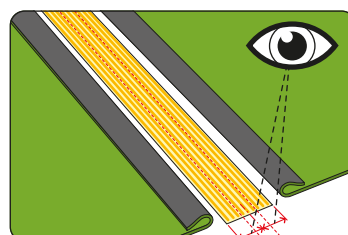

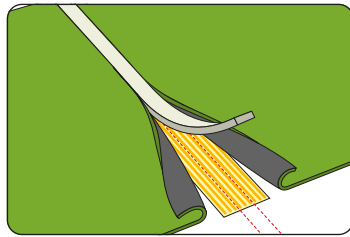

Before placing the turf onto the adhesive, check the correct amount of adhesive by imprinting (the adhesive must be imprinted over the entire backside). Then carefully press the turf edges into the adhesive. Next, gradually begin inserting the cut line, which must be placed on the axis of the cut-out (the ends of the lines can be anchored to prevent them from shifting).

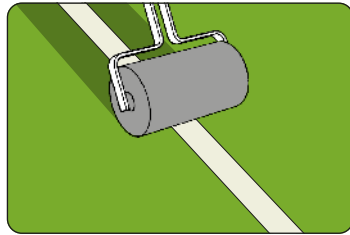

Carefully roll the joint, taking care not to shift the line outside the cut-out area or press it to one side.

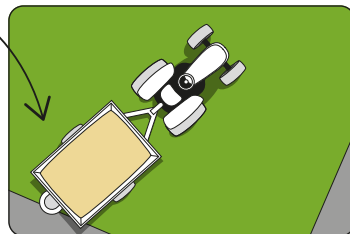
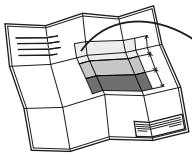

3.3.4. Infill

To determine the correct infill material, height, and quantity, follow the product technical sheet or laboratory test. Neither the turf nor the infill should be wet, as this could result in fibers being buried, which would impair the technical and aesthetic properties of the turf.

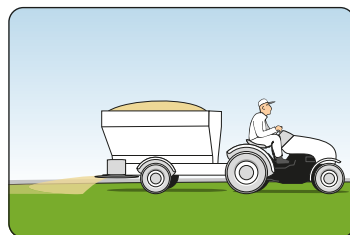

The infill is applied into the artificial turf using special machines that evenly distribute the infill into the turf in the required amount.

TIP: A uniform layer can be achieved using a rotary brush or by brushing with a steel mesh designed for artificial turf.

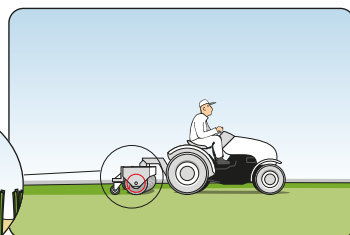

Infill must be applied in small layers. After spreading each layer, brush the infill to achieve an even distribution.

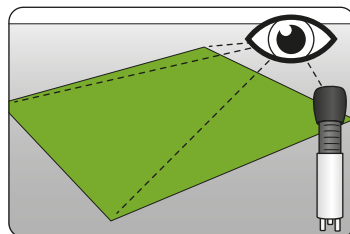
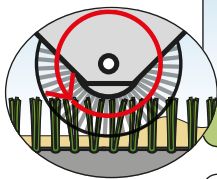

During and after infill application, it is necessary to measure the total height of the infill. If the correct height and type of infill are not maintained, proper playing characteristics and product warranty cannot be guaranteed.

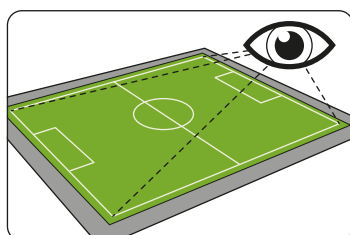

After gluing all joints and completing line marking, it is necessary to check the quality of the individual joints of the rolls and the glued lines.

4. Tools required for installation

A basic set of tools is designated for the installation of artificial turf, intended for handling, cutting, stretching, and gluing the turf. The set should include the following tools:

1 Pressing tool for gluing



2 Circular cutter



3 Glue applicator



4 Line cutter



5 Pliers



6 Edge cutter



7 Turf cutter



8 Backfill height meter



9 Spare blades



10 Special knife



11 Measuring tape



12 Puller



5. Artificial turf maintenance

Systematic and professionally performed maintenance of artificial turf is a basic requirement for its proper operation and for preserving both its physical and functional long-term durability. The intensity of maintenance depends on the frequency of use, the type and degree of contamination (e.g., falling blossoms, leaves, and needles), and the condition of adjacent areas. All activities related to maintenance must be carried out efficiently, thoroughly, and regularly.

Proper maintenance is the basis for:

- surface quality
- long service life
- safety

5.1. Maintenance log keeping

The logbooks allow the operator to record the date, type of activity, and duration of ongoing maintenance, staff training, equipment used, etc.

Maintenance is based on simple principles

- keeping the surface clean
- maintaining the correct infill height and its uniformity
- repairing minor defects before they become more serious

Keeping and archiving the logbook for the lifetime of the product is a condition for the recognition of the product warranty.

5.2. Surface brushing

The main purpose of brushing is to level the infill and ensure surface uniformity. Another important reason is to prevent the fibers from laying down and creating an unwanted flat surface. The fibers always tend to lean in a certain direction; therefore, regular brushing in all directions is important to keep the fibers upright.

5. 2. 1. Intensive Brushing

These are rotary brushes suitable for uprightening fibers that have already laid down and for removing unwanted material from the turf surface, particularly from the upper few millimeters of infill.

Areas subject to heavy use require increased attention. These are the places where surface flatness is most affected due to intensive use.

Recommendation: The most effective brushing of the surface is performed when dry.

Warning: Rotary and straight brushes must not be made of steel bristles or a combination of steel and plastic bristles.

5. 3. Replenishing the Infill

During the use of the artificial turf surface, it is necessary to continuously monitor the infill height and replenish it to the required level. Areas subject to heavy use require increased attention, as they are prone to movement and loss of infill material.

After replenishing the infill, the entire surface must be thoroughly brushed in all directions to achieve even properties.

5. 4. Cleaning and Inspecting the Joints

Machines for cleaning artificial surfaces are divided into machines for removing fine and dust particles and machines for coarse cleaning.

Machines for removing fine dirt, dust, and micro-particles use pneumatic and vacuum systems. This type of cleaning is recommended once a year by a specialized company.

Coarse cleaning of the upper infill layer should be carried out as part of weekly maintenance. Coarse-cleaning machines operate on the principle of sieving the infill through screens. This removes plant debris and other contaminants from the surface.

The growth of algae, moss, and other vegetation can be prevented through regular visual inspections and subsequent mechanical treatment. Timely manual removal of plants prevents their rooting and spread. Plants must be removed manually, without using sharp tools, to avoid damaging the primary backing or fibers.

Inspection of possible joint defects: In case of damage to the turf joints, contact the installation company as soon as possible and insist on immediate repair under the provided warranty. Do not attempt repairs yourself!

5. 5. Snow Removal

When mechanically removing snow, increased caution must be taken to avoid damaging the artificial surface. A front blade with a rubber edge or a snow blower can be used for snow removal. The blade or blower must be set above the turf surface and equipped with guide wheels.

5. 6. Artificial turf inspection

Artificial turf wears out through regular use, as well as due to weather conditions, emissions, etc. Damage can occur mainly through improper use (unsuitable footwear), activities for which the turf was not designed, and insufficient maintenance.

To detect in time whether the turf is damaged or at risk of extensive damage, it must be regularly inspected. Detected defects must be removed immediately.

Late or poorly performed maintenance can cause injuries.

6. Conditions of Use JUTAgrass® Artificial Turf

The following standards must be observed when using areas with artificial turf:

- Only use suitable footwear that does not damage or pull out the fibers. It is forbidden to use shoes with metal soles, studs, spikes, or shoes with soles containing a metal core. Footwear without tread poses a high risk of injury.
- The artificial surface must be used exclusively for the purposes for which it was designed, and not for other activities or sports such as javelin or discus throwing, roller skating, etc.
- The use of chemical agents not approved by JUTA a.s. is prohibited on artificial turf. Some chemicals may have negative effects on the infill and the lifespan of synthetic turf; therefore, we recommend consulting their use in advance with JUTA a.s.
- Over time, depending on the intensity of use, the infill material will be lost and must be regularly replenished to maintain the functional properties of the artificial turf.
- When replenishing the turf infill material, it is necessary to ensure that it has the same quality as the existing infill. The material used for replenishment must be approved for use with the specific type of JUTAgrass® turf.

For safety reasons, smoking and handling open flames on the artificial turf are prohibited. All heat sources can cause irreversible damage to the turf.

Entry onto the artificial turf is permitted only for maintenance machinery intended for turf care and approved by a specialized company or JUTA a.s. The artificial turf must not come into contact with petroleum-based substances, including vehicle fuels. Refueling must always be carried out outside the turf area. In the event of a spill, all leaked liquid must be immediately covered with sand or sawdust and then completely removed. Vehicles moving on the turf surface must be equipped with low-pressure, wide tires. When driving, a low speed must be maintained in curves and a large turning radius must be observed. Sudden braking or acceleration must be avoided. If driving heavy equipment is unavoidable, the artificial turf must be covered along the path to ensure sufficient weight distribution and prevent overloading of the surface. The material used to cover the turf must be carefully selected to avoid damaging the fibers.

Furthermore, the material used to cover the artificial turf must be carefully selected to avoid damaging the fibers. For freely accessible facilities or public areas, construction measures must prevent vehicle entry and uncontrolled use of the sports field. Activities that are not part of sports use are prohibited on the artificial turf surface unless construction modifications, such as covering, are carried out. During such activities, the point loads on the artificial turf system cannot be controlled, which may result in damage.

WARNING!







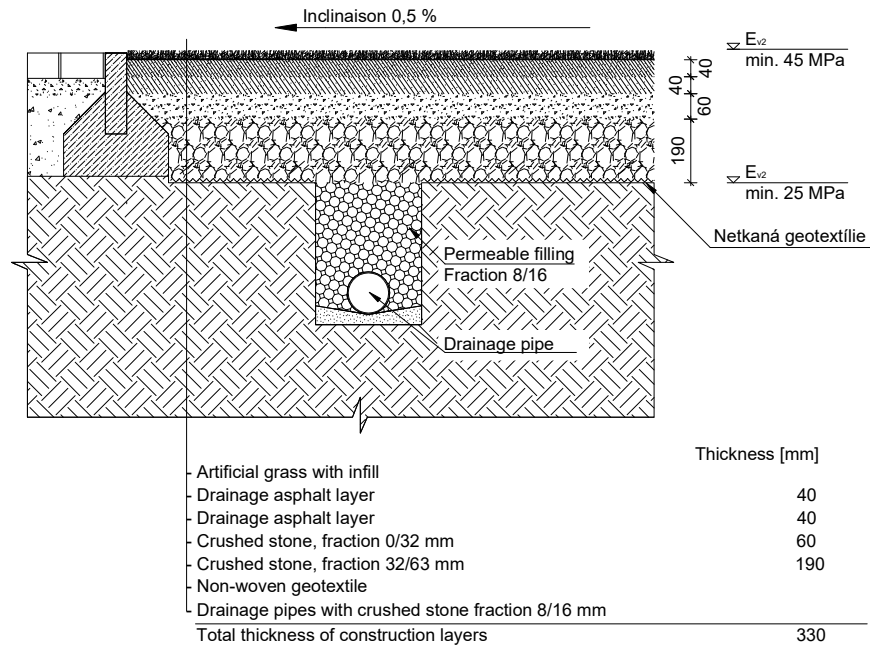



**It is forbidden to handle open flames, smoke,
or set off fireworks on or near the turf.**

7. Appendix – Cross-Section Examples

7.1. Structure with Asphalt Layer



LEGEND:

	Infill		Permeable filling Fraction 8/16		Pavers
	Two-layer drainage asphalt 2 x 40 mm		Sand		Bedding layer
	Crushed stone Fraction 0/32 mm		Existing sub-grade		Crushed stone
	Crushed stone Fraction 32/63 mm		Concrete		

Technical conditions:

- Specified according to DIN 18035-7:2014-05; EN 15330-1
- Surface planarity (measured with 4m straightedge)
 - existing subgrade ± 30 mm
 - construction layer ± 20 mm
 - levelling layer ± 10 mm
- Technical data sheets, certificates, test reports, and declarations of performance must be provided for all materials used.
- Granular materials used for the structural layers must comply with the requirements and standards for the construction of sports fields.
- A geotechnical survey and assessment is required.
- Sub-base must be drained in accordance with the project documentation.
- The substructure layers must be compacted separately, layer by layer, according to their respective aggregate fractions.
 - Minimum degree of compaction for individual layers:
 - existing sub-grade - $E_{def,2} = \text{min. } 25 \text{ MPa}$ verified by static plate load test
 - constructional layers - $E_{def,2} = \text{min. } 45 \text{ MPa}$ verified by static plate load test
- If the final layer is made of crushed aggregate 0/4 mm, it must be compacted in a moist condition.

Note:

- This section depicts a compositional design of our turf system
 - The composition has standard dimensions
 - Actual dimensions will be adjusted according to geotechnical assessment for which the project designer or architect bears responsibility

7.2. Structure with Crushed Aggregate

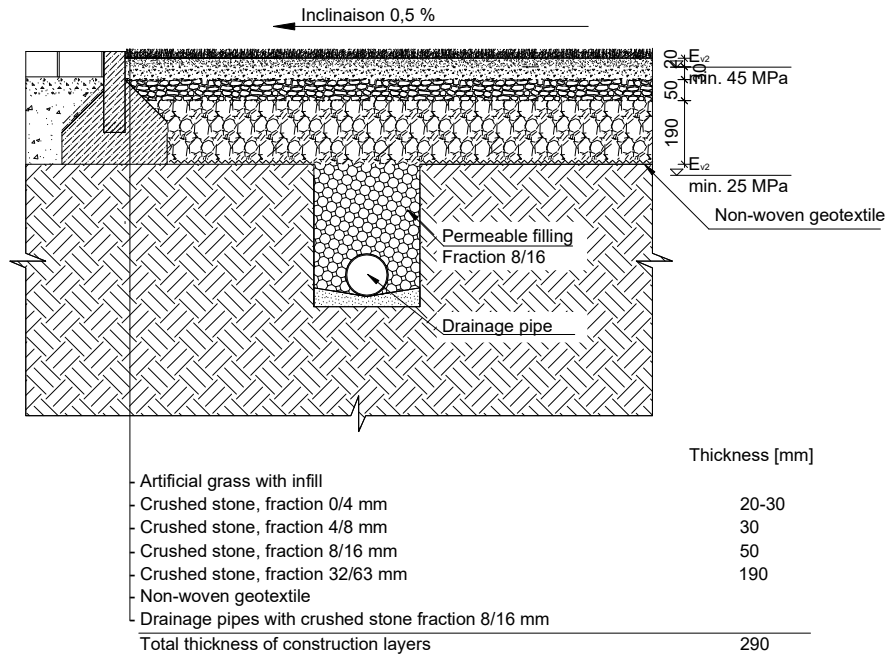

LEGEND:

	Infill		Crushed stone Fraction 32/63 mm		Concrete
	Crushed stone Fraction 0/4 mm		Permeable filling Fraction 8/16		Pavers
	Crushed stone Fraction 4/8 mm		Sand		Bedding layer
	Crushed stone Fraction 8/16 mm		Existing sub-grade		Crushed stone

Technical conditions:

- Specified according to DIN 18035-7:2014-05; EN 15330-1
- Surface planarity (measured with 4m straightedge)
 - existing subgrade ± 30 mm
 - construction layer ± 20 mm
 - levelling layer ± 10 mm
- Technical data sheets, certificates, test reports, and declarations of performance must be provided for all materials used.
- Granular materials used for the structural layers must comply with the requirements and standards for the construction of sports fields.
- A geotechnical survey and assessment is required.
- Sub-base must be drained in accordance with the project documentation.
- The substructure layers must be compacted separately, layer by layer, according to their respective aggregate fractions.
 - Minimum degree of compaction for individual layers:
 - existing sub-grade - $E_{def,2} = \text{min. } 25 \text{ MPa}$ verified by static plate load test
 - constructional layers - $E_{def,2} = \text{min. } 45 \text{ MPa}$ verified by static plate load test
- If the final layer is made of crushed aggregate 0/4 mm, it must be compacted in a moist condition.

Note:

- This section depicts a compositional design of our turf system
 - The composition has standard dimensions
 - Actual dimensions will be adjusted according to geotechnical assessment for which the project designer or architect bears responsibility

8. Instruction Sheet

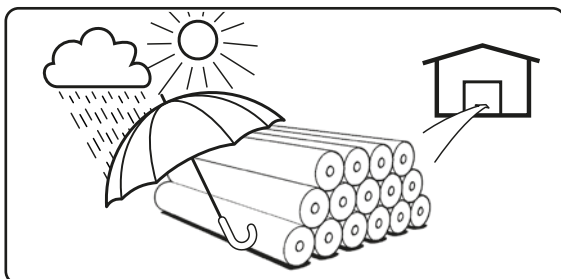
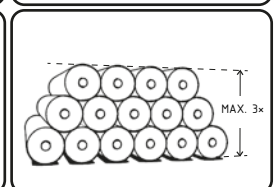
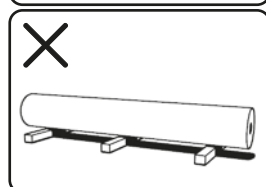
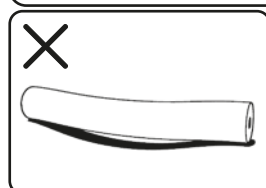
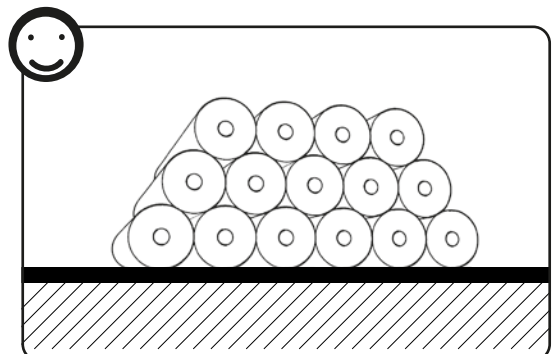
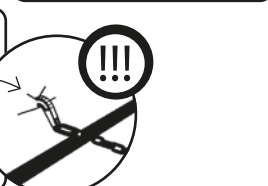
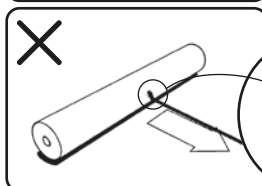
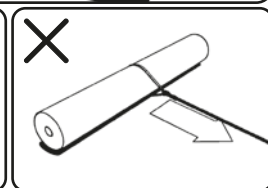
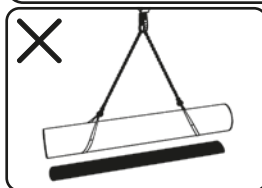
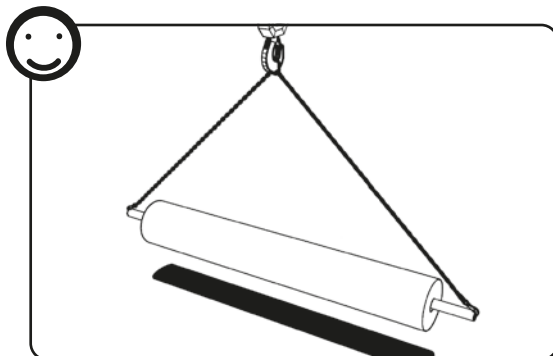
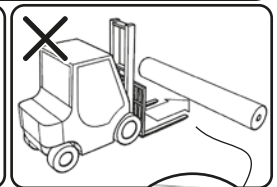
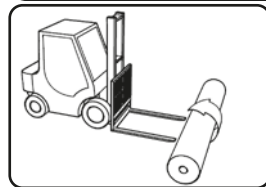
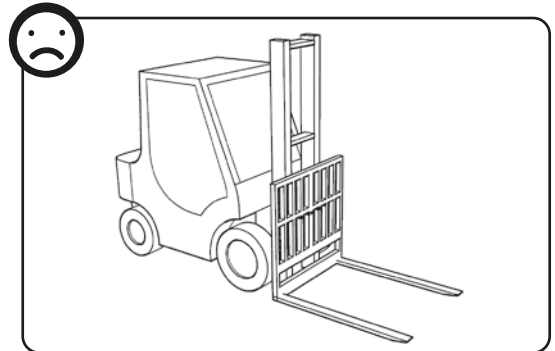
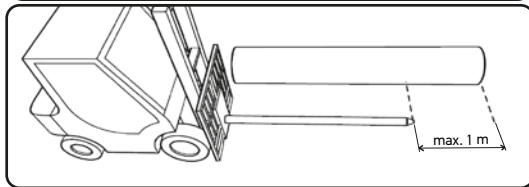
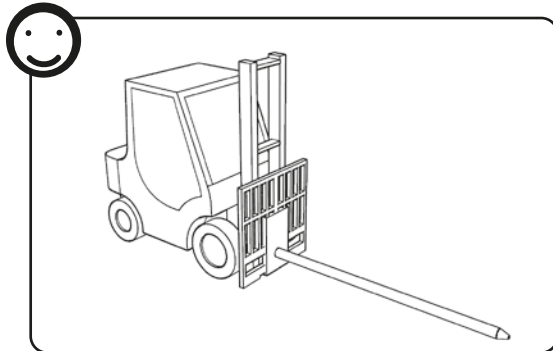

www.jutagrass.cz

Artificial turf under the JUTAgrass® brand is manufactured by
JUTA a.s., Plant 15
Na Borkách 89, 544 01 Dvůr Králové nad Labem
Česká republika
Tel.: +420 499 314 567
www.jutagrass.cz | jutagrass@juta.cz